

固定板詳細

No.	PART NAME	STANDARD/SIZE	MATERIAL	QTY	NOTE
1	パイプ脚	φ 34× t2× L430	SUS304	4	
2	補強パイプ(A)	φ 16× t1× L340	SUS304	2	
3	補強パイプ(B)	φ 16× t1× L516	SUS304	2	
4	取付座(A)	L620× W50× t12	SUS304	2	
5	取付座(B)	L320× W50× t12	SUS304	1	
6	固定板	t1.5	SUS304	1	
7	キャスター取付座		SUS304	4	4-005021
8	キャスター(A)ストッパー付	315SA-UB-75/ハンマー	SUS/カワチ車	2	
9	キャスター(B)	320SA-UB-75/ハンマー	SUS/カワチ車	2	
10	六角ボルト	M10× L50	SUS304	2	
11	六角低ナット	M10	SUS304	2	

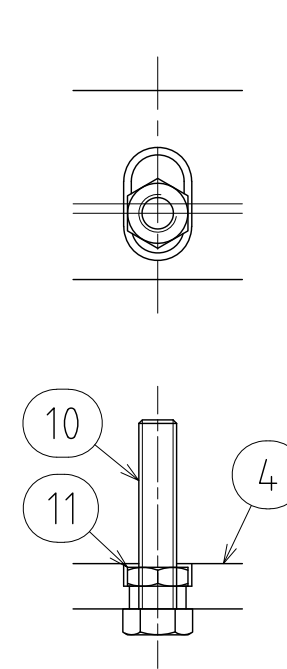

A部詳細 S=1:2

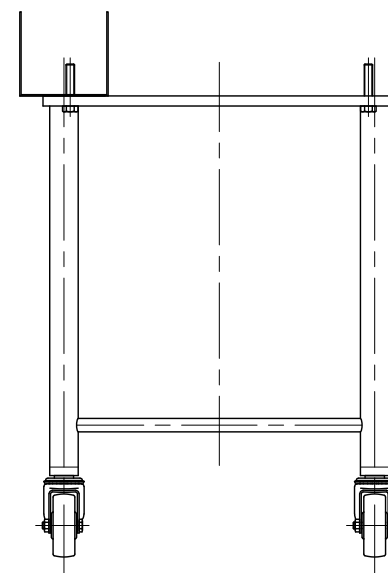
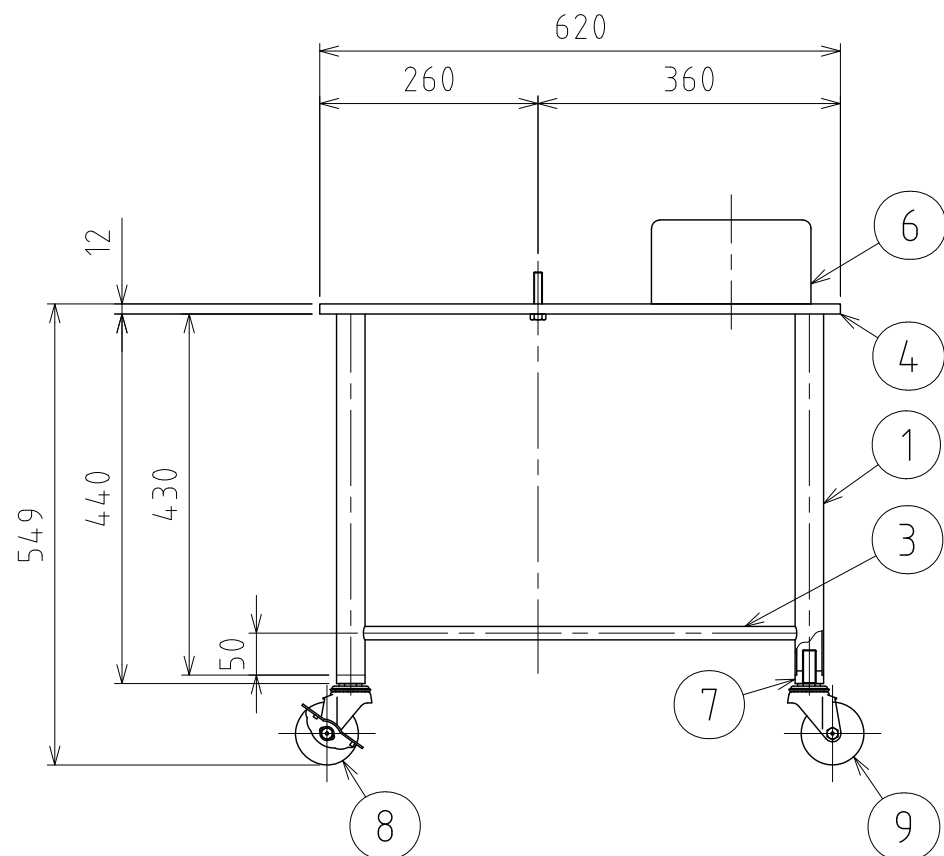
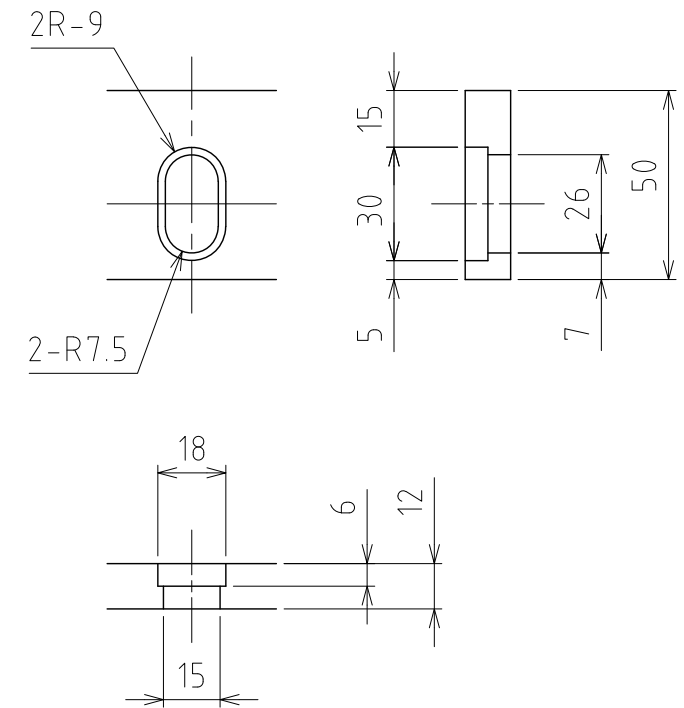

A部(ザグリ)詳細 S=1:2

注記  
仕上げ：バフ研磨、溶接部ビートカット

DESIGN	DATE	NAME	TM 架台
DRAWN	DATE	DWG NO.	TM-30(S)
CHECKED	DATE	SCALE	3-003572-1
APPROVED	DATE	SCALE	1:9 CUSTOMER
		SANKO ASTEC INC.	

△ <sup>8</sup>	2018/02/07		
MARK	DATE	REV	APPROVED
板金溶接組立の寸法許容差は±1%又は5mmの大きい値			