

File # 030243-0

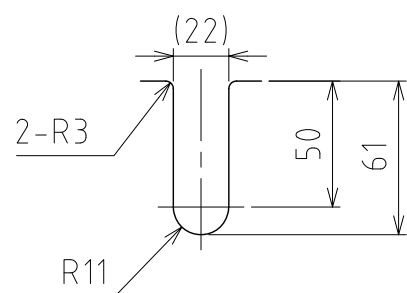

袴切欠き詳細図

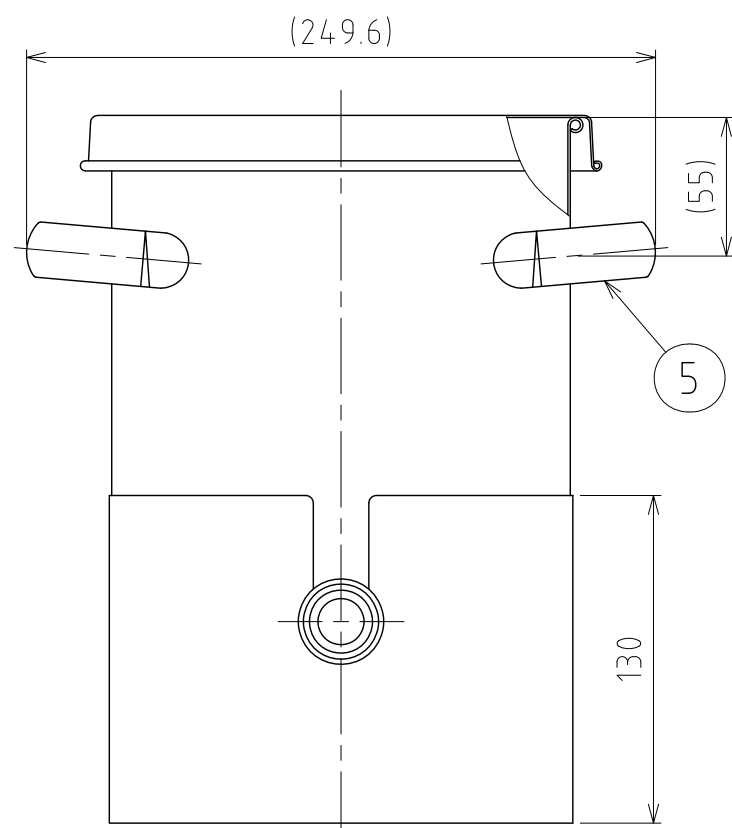
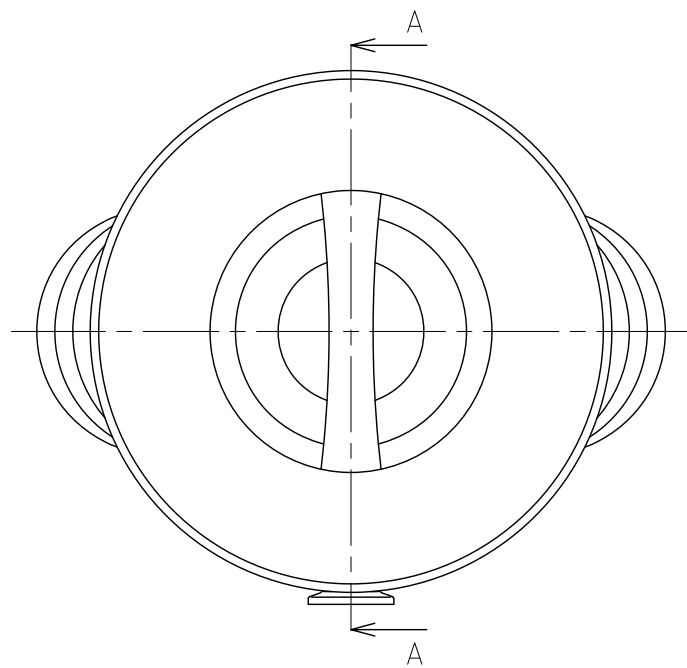
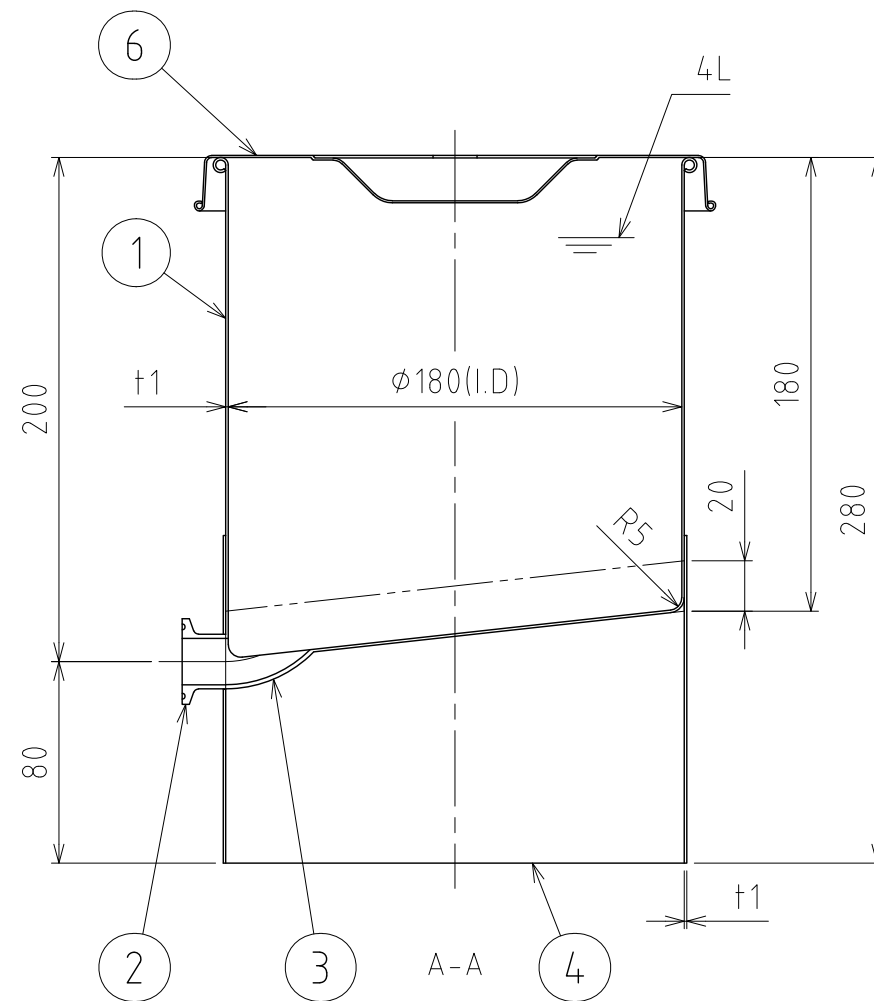

No.	PART NAME	STANDARD/SIZE	MATERIAL	QTY	NOTE
1	容器本体		SUS304	1	
2	ヘルール	ISO 15A $\phi 23$ (I.D) L17.3	SUS316L	1	
3	90°エルボ	15A $\phi 23$ (I.D)	SUS316L	1	
4	袴		SUS304	1	
5	取っ手	S	SUS304	2	
6	ストック蓋	S-18 (+0.8)	SUS304	1	

注記
 容量：4L
 仕上げ：内外面# 320バフ研磨
 取っ手の取付は、スポット溶接
 袴の取付は、断続溶接
 二点鎖線は、周溶接位置

DESIGN	DATE
-	2023/12/01
DRAWN	DATE
-	-
CHECKED	DATE
-	-
APPROVED	DATE
-	-

MARK	DATE	REV	APPROVED
板金溶接組立の寸法許容差は±1%又は5mmの大きい値			
NAME	スロープ容器 KT-ST-18		
DWG NO.	3-030243-0		
SCALE	1:3	CUSTOMER	規格図

SANKO ASTEC INC.